

SPIROL[®]

SLOTTED SPRING PINS



Slotted Spring Pins are general purpose components used in various fastening applications. Compressed as it is installed, the pin applies continuous pressure on the sides of the hole wall. The primary spring action of the Slotted Pin is focused on the area opposite the slot as the two halves of the pin compress during installation. This flexibility allows Slotted Spring Pins to accommodate wider hole tolerances than rigid Solid Pins which results in reduced manufacturing costs of the mating component.

WHY SPIROL® SLOTTED PINS ARE THE PINS OF CHOICE

- SPIROL Standard Slotted Pins have a slot width narrower than the wall thickness and thus do not nest or interlock. This feature, combined with a smaller expanded (pre-insertion) diameter, results in numerous advantages compared to other types of Slotted Pins:
 - Lower insertion force and smoother insertion
 - Rounder pins, which in turn results in better conformance of the pin to the hole wall and eliminates the edge of the slot damaging the hole during insertion.
 - Lower stress in the spine (directly opposite the slot) of the installed pin. This results in longer pin life in shock or fatigue applications.
 - Ability to use automatic vibratory feeding of pins for installation without interlocking.
 - Plating of pins for additional corrosion resistance or appearance without “touch marks”, unplated areas, or the bonding of nested pins.
- SPIROL uses a micrometre to ensure that the diameter is within specification around the entire periphery of the pin (except directly on the slot). Some industry standards only take the average diameter measurement at 3 points or use ring gauges; often resulting in oblong shaped parts.
- SPIROL specifies a maximum chamfer diameter of 0.1 to 0.5mm smaller than the nominal (smallest) hole diameter, whereas some industry standards only state that the chamfer must be smaller than nominal.
- Based on a closely controlled in-house heat treating process, the rounder pin and narrower slot, SPIROL is able to control straightness for our Slotted Pins. Other Slotted Pins have a tendency to arch during heat treating.
- SPIROL Standard high carbon steel Slotted Pins have a higher shear strength than other industry standards based on the thicker wall thickness.
- SPIROL Standard Slotted Pins manufactured from austenitic stainless steel have shear strength specifications whereas some industry standards do not.
- Given that SPIROL has in-house, state-of-the-art heat treating equipment and a closely controlled and monitored hardening process, SPIROL Standard Slotted Pins are also offered in martensitic stainless steel as stocked items.
- SPIROL offers mechanical zinc plated Slotted Pins as a standard product, eliminating the risk of hydrogen embrittlement associated with electroplated zinc.





WHY SPIROL SHOULD BE YOUR VENDOR OF CHOICE FOR SLOTTED SPRING PINS

- SPIROL has over 75 years of experience in producing quality pins with full lot traceability back to the raw material. Raw materials are RoHS, REACH, Conflict Mineral, and DFARS compliant.
- SPIROL has a global footprint with a physical presence in the US, Canada, Mexico, Brazil, England, France, Germany, Spain, Poland, Czech Republic, China and South Korea.
- SPIROL's production facilities are IATF 16949, ISO 9001, and ISO 14001 certified. The customer is assured that each shipment is from the same source produced on the same equipment to the highest quality standard.
- SPIROL is a direct supplier to the brand OEM automotive companies as well as to other tier 1 and 2 companies in the automotive industry and is fully versed in the high standards and demands of that industry.
- SPIROL is the only company that standardizes and inventories both metric and imperial sizes.
- SPIROL is large enough to invest in state-of-the-art equipment necessary to meet today's production and quality standards, but small enough to have the flexibility to meet customer's unique needs.
- SPIROL has the widest range of product, generally ships from stock, and has the ability to respond to unplanned demands quickly.
- SPIROL's sales engineers and engineering staff partner with each customer to determine the best solution to meet the customer's performance and assembly needs or to resolve a design or supply chain issue.
- SPIROL has expertise in assembly and installation of pins with a standard line of state-of-the-art Pin Insertion Machines - from manual to fully automatic modules.

SPIROL stands apart from all other companies in our industry. We are a technical resource who provides high quality components that improve the quality of your assembly, extend the life of your products and reduce your manufacturing costs.

Local Design, Global Supply

SPIROL has Application Engineers throughout the world to assist you in your designs, supported by state-of-the-art manufacturing centres and worldwide stocking facilities to simplify the logistics of delivering your product.



North America

South America

Europe

Asia/Pacific

Contact **SPIROL** for design assistance:
www.SPIROL.ca



MATERIAL	FINISHES
B High Carbon Steel	K Plain, Oiled*
C Martensitic Stainless Steel	T Mechanical Zinc
D Austenitic Stainless Steel	

*Austenitic stainless steel pins are not oiled.

IDENTIFICATION CODE

Slotted Pin 6mm diameter x 32mm length carbon steel/plain finish

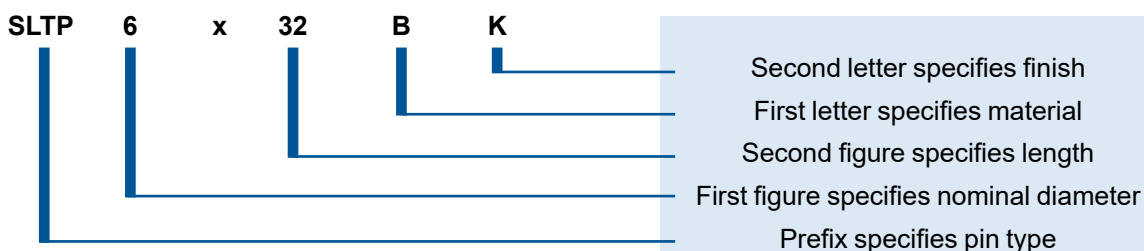

HOW TO MEASURE THE DIAMETER OF A SLOTTED SPRING PIN

SPIROL Standard Slotted Pins are manufactured and inspected to be within diameter specifications along the full diameter with the exception of the slot region. The outside diameter is to be measured with a micrometre per the schematic below. The pin must also pass through a go ring gauge.

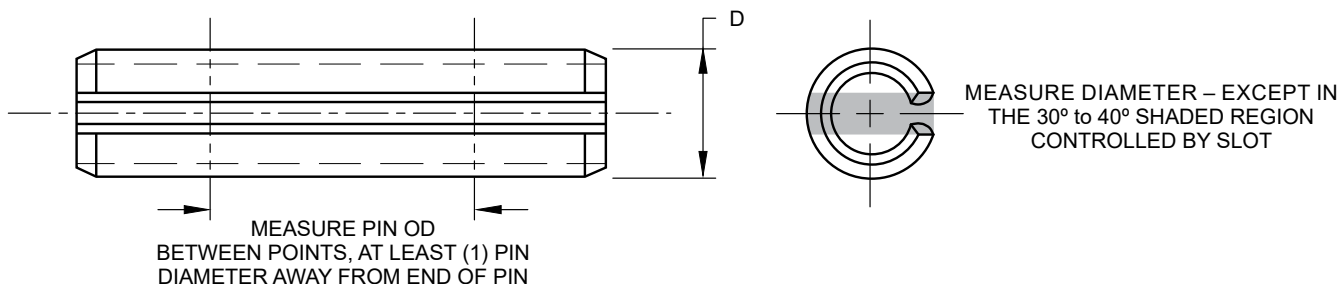

NOTES

- All dimensions apply prior to plating
- The standard finish for stainless steel pins is plain (K). Passivated (P) pins are available at an additional cost.
- Special sizes, materials and finishes, including oil-free pins, are available upon request.

STANDARD METRIC

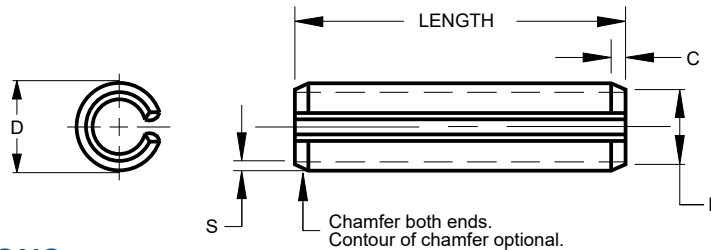

DESIGNED FOR AUTOMATIC FEEDING AND INSTALLATION

METRIC SPECIFICATIONS

NOMINAL DIAMETER		1.5	2	2.5	3	4	5	6	8	10	12
DIAMETER ØD	MAX.	1.66	2.19	2.72	3.25	4.30	5.33	6.36	8.45	10.51	12.55
	MIN.	1.58	2.10	2.62	3.14	4.16	5.17	6.18	8.22	10.25	12.28
CHAMFER DIAMETER B	MAX.	1.4	1.9	2.4	2.9	3.9	4.8	5.8	7.8	9.7	11.7
CHAMFER LENGTH C	MAX.	0.7	0.8	0.9	1.0	1.2	1.4	1.6	2.0	2.4	2.8
	MIN.	0.15	0.2	0.2	0.2	0.3	0.3	0.4	0.4	0.5	0.6
WALL THICKNESS S	NOMINAL	0.35	0.45	0.55	0.65	0.8	1.0	1.2	1.6	2.0	2.5
RECOMMENDED HOLE SIZE	MAX.	1.56	2.07	2.58	3.10	4.12	5.12	6.12	8.15	10.15	12.18
	MIN.	1.5	2.00	2.50	3.00	4.00	5.00	6.00	8.00	10.00	12.00
MIN. DOUBLE SHEAR STRENGTH, kN ¹	CARBON & MARTENSITIC SST	1.8	3.5	5.5	7.8	12.3	19.6	28.5	48.8	79.1	104.1
	AUSTENITIC SST	1.0	2.0	3.2	4.5	7.2	11.4	16.6	28.4	46.1	—

STANDARD SIZES

NOMINAL DIAMETER		1.5	2	2.5	3	4	5	6	8	10	12
LENGTH	4	*									
	5	*	*								
	6	*	*	*	*						
	8	*	*	*	*	*					
	10	*	*	*	*	*					
	12	*	*	*	*	*	*	*			
	14	*	*	*	*	*	*	*	*		
	16	*	*	*	*	*	*	*	*	*	
	18	*	*	*	*	*	*	*	*	*	*
	20	*	*	*	*	*	*	*	*	*	*
	22	*	*	*	*	*	*	*	*	*	*
	24		*	*	*	*	*	*	*	*	*
	26			*	*	*	*	*	*	*	*
	28			*	*	*	*	*	*	*	*
	30			*	*	*	*	*	*	*	*
	32				*	*	*	*	*	*	*
	35				*	*	*	*	*	*	*
	40				*	*	*	*	*	*	*
	45					*	*	*	*	*	*
	50						*	*	*	*	*
55							*	*	*	*	
60								*	*	*	
65								*	*	*	
70								*	*	*	
75								*	*	*	
80								*	*	*	
85									*	*	
90										*	
95										*	
100										*	

Nominal Pin Length	Gauge Length	Gauge Hole Diameter = Maximum Pin Diameter Plus:	
		MIN.	MAX.
Up to 24mm incl.	25mm ± 0.15mm	0.20mm	0.22mm
24mm – 50mm	50mm ± 0.15mm	0.40mm	0.43mm
Over 50mm	75mm ± 0.15mm	0.60mm	0.64mm

Straightness Gauge Specifications ²			
Nominal Pin Length	Gauge Length	Gauge Hole Diameter = Maximum Pin Diameter Plus:	
		MIN.	MAX.
Up to 24mm incl.	25mm ± 0.15mm	0.20mm	0.22mm
24mm – 50mm	50mm ± 0.15mm	0.40mm	0.43mm
Over 50mm	75mm ± 0.15mm	0.60mm	0.64mm

	Available in high carbon (B) and stainless steel (C, D)
	Only available in high carbon (B)
*	Generally stocked size

¹ Shear tests performed in accordance with ASME B18.8.4M & ISO 8749

² The straightness over the length of the pin shall be such that the pin will pass freely through a ring gauge of the length and diameter specified.

- All dimensions apply prior to plating
- Other sizes and materials available to order
- ASME B18.8.4M Type B is based on SPIROL's specifications. SPIROL Standard Slotted Pins meet or exceed ASME B18.8.4M Type B.

ISO 8752 METRIC

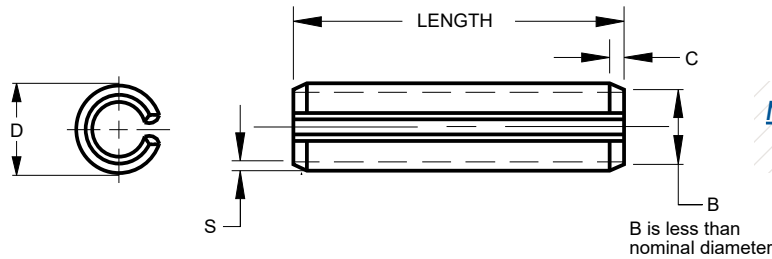

NOT RECOMMENDED FOR AUTOMATIC FEEDING AND INSTALLATION

METRIC SPECIFICATIONS

NOMINAL DIAMETER		2	2.5	3	3.5	4	4.5	5	6	8	10	12
DIAMETER ØD	MAX.	2.4	2.9	3.5	4.0	4.6	5.1	5.6	6.7	8.8	10.8	12.8
	MIN.	2.3	2.8	3.3	3.8	4.4	4.9	5.4	6.4	8.5	10.5	12.5
CHAMFER LENGTH C	MAX.	0.55	0.60	0.70	0.80	0.85	1.00	1.10	1.40	2.00	2.40	2.40
	MIN.	0.35	0.40	0.50	0.60	0.65	0.80	0.90	1.20	1.60	2.00	2.00
WALL THICKNESS S	NOMINAL	0.4	0.5	0.6	0.75	0.8	1.0	1.0	1.2	1.5	2.0	2.5
RECOMMENDED HOLE SIZE	MAX.	2.10	2.60	3.10	3.62	4.12	4.62	5.12	6.12	8.15	10.15	12.18
	MIN.	2.00	2.50	3.00	3.50	4.00	4.50	5.00	6.00	8.00	10.00	12.00
MIN. DOUBLE SHEAR STRENGTH HIGH CARBON STEEL, kN ¹		2.82	4.38	6.32	9.06	11.24	15.36	17.54	26.04	42.76	70.16	104.1

STANDARD SIZES

NOMINAL DIAMETER		2	2.5	3	3.5	4	4.5	5	6	8	10	12
LENGTH	4											
	5											
	6	*	*									
	8	*	*	*								
	10	*	*	*		*						
	12	*	*	*		*		*				
	14	*	*	*		*		*	*			
	16	*	*	*		*		*	*			
	18	*	*	*		*		*	*	*		
	20	*	*	*		*		*	*	*		
	22	*	*	*		*		*	*	*	*	
	24	*	*	*		*		*	*	*	*	*
	26	*	*	*		*		*	*	*	*	*
	28	*	*	*		*		*	*	*	*	*
	30	*	*	*		*		*	*	*	*	*
	32			*		*		*	*	*	*	*
	35			*		*		*	*	*	*	*
	40			*		*		*	*	*	*	*
	45					*		*	*	*	*	*
	50					*		*	*	*	*	*
55							*	*	*	*	*	
60								*	*	*	*	
65								*	*	*	*	
70								*	*	*	*	
75									*	*	*	
80										*	*	
85											*	
90											*	
95											*	
100											*	

Nominal Pin Length	Length Tolerance
Length Tolerance - ISO 8752	
4mm to 10mm	± 0.25mm
12mm to 50mm	± 0.50mm
55mm to 100mm	± 0.75mm
Length Tolerance - DIN 1481 (Ref)	
4mm to 10mm	+ 0.5mm
12mm to 50mm	+ 1.0mm
55mm to 100mm	+ 1.5mm

Only available in high carbon (B) and austenitic stainless steel (D)

Only available in high carbon (B)

* Generally stocked size

¹ Shear tests performed in accordance with ISO 8749. Shear strength for austenitic stainless steel is not specified.

• Other sizes and materials available to order

STANDARD INCH

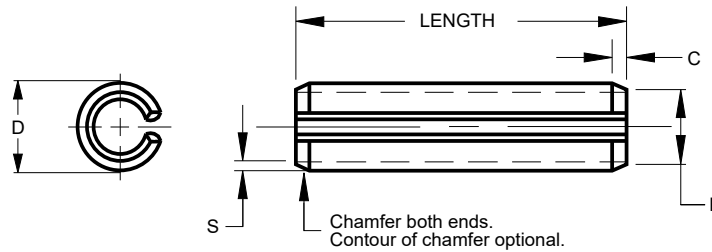

DESIGNED FOR AUTOMATIC FEEDING AND INSTALLATION

INCH SPECIFICATIONS

NOMINAL DIAMETER ▶		.062 1/16	.078 5/64	.094 3/32	.125 1/8	.156 5/32	.187 3/16	.219 7/32	.250 1/4	.312 5/16	.375 3/8	.437 7/16	.500 1/2	
DIAMETER ØD	MAX.	.069	.086	.103	.135	.167	.199	.232	.264	.330	.395	.459	.524	
	MIN.	.066	.083	.099	.131	.162	.194	.226	.258	.321	.385	.448	.513	
CHAMFER DIAMETER B	MAX.	.059	.075	.091	.122	.151	.182	.214	.245	.306	.368	.430	.485	
	MIN.	.028	.032	.038	.044	.048	.055	.065	.065	.080	.095	.095	.110	
CHAMFER LENGTH C	MAX.	.028	.032	.038	.044	.048	.055	.065	.065	.080	.095	.095	.110	
	MIN.	.007	.008	.008	.008	.010	.011	.011	.012	.014	.016	.017	.025	
WALL THICKNESS S	NOMINAL	.012	.018	.022	.028	.032	.040	.048	.048	.062	.077	.077	.094	
RECOMMENDED HOLE SIZE	MAX.	.065	.081	.097	.129	.160	.192	.224	.256	.318	.382	.448	.510	
	MIN.	.062	.078	.094	.125	.156	.187	.219	.250	.312	.375	.437	.500	
MIN. DOUBLE SHEAR STRENGTH ¹	CARBON & MARTENSITIC SST	LBS.	430	800	1,150	1,875	2,750	4,150	5,850	7,050	10,800	16,300	19,800	27,100
		kN.	1.91	3.56	5.12	8.34	12.23	18.46	26.02	31.36	48.04	72.51	88.08	120.55
	AUSTENITIC SST	LBS.	250	460	670	1,090	1,600	2,425	3,400	4,100	6,300	9,500	11,500	15,800
		kN.	1.11	2.05	2.98	4.85	7.12	10.79	15.12	18.24	28.02	42.26	51.15	70.28

STANDARD SIZES

NOMINAL DIAMETER ▶		.062 1/16	.078 5/64	.094 3/32	.125 1/8	.156 5/32	.187 3/16	.219 7/32	.250 1/4	.312 5/16	.375 3/8	.437 7/16	.500 1/2
LENGTH	.187 3/16	*	*	*									
	.250 1/4	*	*	*	*								
	.312 5/16	*	*	*	*								
	.375 3/8	*	*	*	*	*	*						
	.437 7/16	*	*	*	*	*	*						
	.500 1/2	*	*	*	*	*	*	*	*				
	.562 9/16	*	*	*	*	*	*	*	*				
	.625 5/8	*	*	*	*	*	*	*	*	*			
	.687 11/16	*	*	*	*	*	*	*	*	*			
	.750 3/4	*	*	*	*	*	*	*	*	*	*		
	.812 13/16	*	*	*	*	*	*	*	*	*	*		
	.875 7/8	*	*	*	*	*	*	*	*	*	*	*	
	.937 15/16	*	*	*	*	*	*	*	*	*	*	*	*
	1.000 1	*	*	*	*	*	*	*	*	*	*	*	*
	1.125 1-1/8		*	*	*	*	*	*	*	*	*	*	*
	1.250 1-1/4		*	*	*	*	*	*	*	*	*	*	*
	1.375 1-3/8		*	*	*	*	*	*	*	*	*	*	*
	1.500 1-1/2		*	*	*	*	*	*	*	*	*	*	*
	1.625 1-5/8					*	*	*	*	*	*	*	*
	1.750 1-3/4					*	*	*	*	*	*	*	*
1.875 1-7/8					*	*	*	*	*	*	*	*	
2.000 2					*	*	*	*	*	*	*	*	
2.250 2-1/4						*	*	*	*	*	*	*	
2.500 2-1/2						*	*	*	*	*	*	*	
2.750 2-3/4								*	*	*	*	*	
3.000 3								*	*	*	*	*	
3.250 3-1/4													
3.500 3-1/2													
3.750 3-3/4													
4.000 4													

Straightness Gauge Specifications ²		
Nominal Pin Length	Gauge Length	Gauge Hole Diameter = Maximum Pin Diameter Plus:
Up to 1"	1.000" ± .005"	.007"
1" – 2"	2.000" ± .005"	.010"
Over 2"	3.000" ± .005"	.013"

Available in high carbon (B) and stainless steel (C, D)
* Generally stocked size

¹ Shear tests performed in accordance with ASME B18.8.2.

² The straightness over the length of the pin shall be such that the pin will pass freely through a ring gauge of the length and diameter specified.

- All dimensions apply prior to plating
- Other sizes and materials available to order
- ASME B18.8.2 is based on SPIROL's specifications. SPIROL Standard Slotted Pins meet or exceed ASME B18.8.2.

CARBON STEELS

Carbon steels are the most cost effective and versatile materials available for use in Slotted Spring Pins. These materials are readily available, easy to process, and have very uniform and predictable performance characteristics. The most noticeable limitation to these materials is corrosion protection. In most applications, the normal rust preventative oil is adequate for corrosion protection. In cases where extra protection is necessary, the benefits of supplemental coatings and stainless steel must be evaluated.

High Carbon Steel (B)

High carbon steel is one of the most versatile materials available. It provides very good shear strength and fatigue life suitable for most applications. This material is readily available, and is the most economical of all standard Slotted Pin materials in the absence of any plating or coating. The recommended service temperatures for high carbon steel Slotted Pins are between -45°C (-50°F) and 150°C (300°F). High carbon Slotted Spring Pins are heat treated and have a dry to the touch rust preventative. Additional coatings and finishes can be applied to carbon steel to improve corrosion resistance, however for some applications, it may be more appropriate and cost beneficial to specify stainless steel when a high level of corrosion resistance is required.

TYPE	GRADE	HARDNESS, VICKERS	
		SPIROL Standard	ISO 8752
B - High Carbon Steel	UNS G10700 / G10740 C67S (1.1231) / C75S (1.1248)	HV 458 – 560	HV 420 – 520
D - Stainless Steel, Austenitic	UNS S30200 / S30400 18-8 (1.4310)	Work Hardened	Work Hardened
C - Stainless Steel, Martensitic	UNS S42000 X30Cr13 (1.4028)	HV 423 – 544	*HV 440 – 560

STAINLESS STEELS

In applications where extended corrosion protection is required, stainless steel Slotted Spring Pins are available. There are two basic classifications of stainless steel used for manufacturing Slotted Pins; austenitic stainless and martensitic stainless.

Austenitic Stainless Steel (D)

Austenitic stainless steel provides the best corrosion protection against normal environmental conditions in both oxygenating and non-oxygenating atmospheres. It withstands fresh water and atmospheric marine conditions very well, and is suitable for many other industrial conditions including acidic environments. However, this material is not heat treated and therefore it is not as strong as the high carbon and martensitic stainless steels, and does not have the fatigue resistance of those materials. Austenitic stainless steel Slotted Pins are not recommended for high shock and vibration applications, and they should never be installed into hardened holes. Austenitic stainless steel Slotted Spring Pins can be used in temperatures as low as -185°C (-300°F) and as high as 400°C (750°F).

Martensitic Stainless Steel (C)

Martensitic stainless steel provides both good corrosion resistance and excellent strength and fatigue properties.

Martensitic stainless steel is not as corrosion resistant as austenitic stainless in non-oxygenating atmospheres, but it withstands the most common atmospheric and environmental conditions in the presence of free oxygen. The service temperatures for martensitic stainless steel Slotted Pins should be restricted to a minimum of -45°C (-50°F) and a maximum of 260°C (500°F). Martensitic stainless steel Slotted Spring Pins are hardened and stress relieved in-house.

**Made to order*

SPECIAL MATERIALS

SPIROL has extensive experience with special materials required for unique circumstances such as:

Beryllium Copper (I)

Beryllium Copper is one of the strongest of all non-ferrous materials. It is precipitation hardened to a hardness of approximately HV 392 (Rc 40). The resulting shear strength is about 10% greater than that of austenitic stainless steel. In addition to being completely non-magnetic, beryllium copper has very good electrical and thermal conductivity properties. It has fatigue strength characteristics nearly as good as martensitic stainless steel, and superior galling and wear resistance. It has excellent corrosion resistance in salt water and polluted waters as compared to stainless steel, and is not susceptible to hydrogen embrittlement. The recommended service temperatures for beryllium copper is between -185°C (-300°F) to 260°C (500°F), making it an ideal material for cryogenic applications.

316 Stainless Steel (S)

For severe environments, such as when the pin is submerged in seawater or when used in the petrochemical industry, 316 stainless steel exhibits superior resistance to pitting. This is due to the higher nickel content and, in particular, the addition of molybdenum which significantly increases the chemical resistance of this alloy. This alloy is also austenitic, non-magnetic and non-hardenable using conventional methods. The recommended service temperatures for 316 stainless steel is between -185°C (-300°F) and as high as 870°C (1,300°F).

Other materials and finishes are available to order depending on the application requirements.

Protective finishes are generally used to improve the corrosion resistance of the base metal. There are many different coating types, such as electroplating, chemical conversion, immersion, and mechanical applications. Each of these processes has limitations when applied to Slotted Spring Pins, and depending on the application there may be other concerns. **SPIROL** has extensive experience in recommending and selecting the right combination of material and finish for a variety of applications.

Given the propensity for ISO Slotted Pins to interlock during processing, only SPIROL Standard Slotted Pins are available with any protective finish other than plain, oiled.

STANDARD FINISHES

Plain, Oiled (K)

This finish is a thin coating of dry-to-the touch oil that provides corrosion resistance during storage and shipping. Since this lubricating oil is suspended in a carrier which evaporates over time, the pins are dry-to-the-touch and conducive for automatic feeding and assembly.

Mechanical Zinc (T)

This finish consists of a minimum thickness of 8 μm (.0003") mechanically deposited zinc with a supplementary treatment of clear trivalent passivation. Zinc plating prevents galvanic corrosion and provides moderate atmospheric corrosion protection. If severe conditions exist, a stainless steel pin should be considered.

SPIROL does not electroplate Slotted Spring Pins due to the risk of hydrogen embrittlement.

AVAILABLE TO ORDER

Zinc Phosphate (R)

This zinc phosphate finish has a minimum coating weight of 11 g/m², and is used to provide a good surface on carbon steel for subsequent operations such as painting or oiling. On its own, zinc phosphate provides no corrosion protection. A dry-to-the-touch lubricating oil is added to phosphate coated pins to provide corrosion resistance during storage and shipping. This coating is mostly used for legacy applications, particularly in the firearms and military industries, and is rarely specified on new applications.

For military applications, a different protective oil is applied to the zinc phosphate than that used for commercial products. The more viscous oil is not suitable for automatic feeding.

Passivated (P)

While stainless steel Slotted Spring Pins are normally provided with a plain finish, passivation is available to meet application specific requirements. Passivation of Slotted Pins is a process whereby surface contaminants such as embedded tool steel and other free iron particles are removed. The purpose of passivation is to remove embedded iron and apply a controlled oxide layer to the pin. However, many applications simply do not require passivation. Examples of critical applications where passivation is appropriate are medical devices, components used in the food or drug industry, fuel system applications, and any application requiring a clean environment.

Available only for stainless steel.

Oil Free (F)

Oil free pins undergo a special cleaning process to remove oil residues from the parts. This finish option is typically recommended for pins used in plastics that are incompatible with hydrocarbon based oils and thus susceptible to environmental stress corrosion cracking, as well as for medical or food processing applications.

Available only for stainless steel.

Additional special finishes are available upon request.

WHAT IS SHEAR STRENGTH?

The shear strength of a Slotted Pin is determined by the maximum amount of force the pin can withstand before it breaks when the force is applied perpendicular to the axis of the pin. Pins can be sheared in multiple planes, for example, a pin that breaks in single shear would result in two separate pieces of the pin, whereas a pin that breaks in double shear would result in three separate pieces of the pin.

The three prevailing industry standards (ASME, ISO, and JIS) specify a minimum shear strength for Slotted Spring Pins and specific parameters under which the shear test is to be performed. The intent of performing the shear test is to verify that the pin has been formed properly from the correct size and type of raw material, and subsequently processed (e.g. heat treated) to meet the minimum shear strength specified. The shear values listed on pages 3-5 will only be obtained when tested in accordance with the applicable specifications.

The fact that a pin passes the shear test can be misleading as most applications have different conditions than those specified in the shear test specification. This includes the rate of the load applied, hardness of the host material, the distance between the shear planes, and the distance from each end of the pin. Any difference(s) between the actual application and the testing parameters will affect the shear load that can be achieved by the pin. The shear strength data in the catalogue should only be used as a guideline and not to determine application specific capabilities. *SPIROL recommends that acceptance of any pin be based on validation and approval of the assembly.*

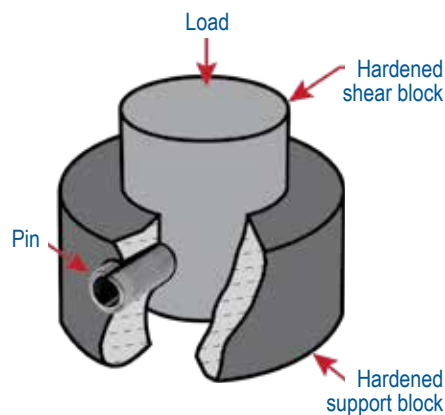
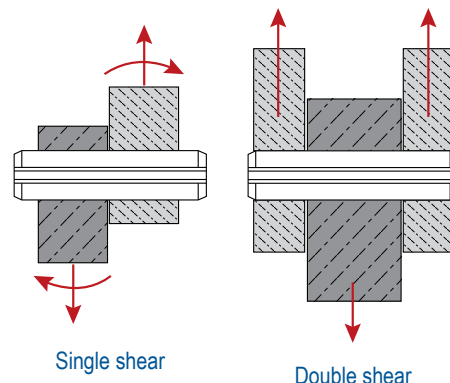

Shear test performed in a fixture per ISO 8749

ORIENTATION OF SLOT AFFECTS SHEAR STRENGTH

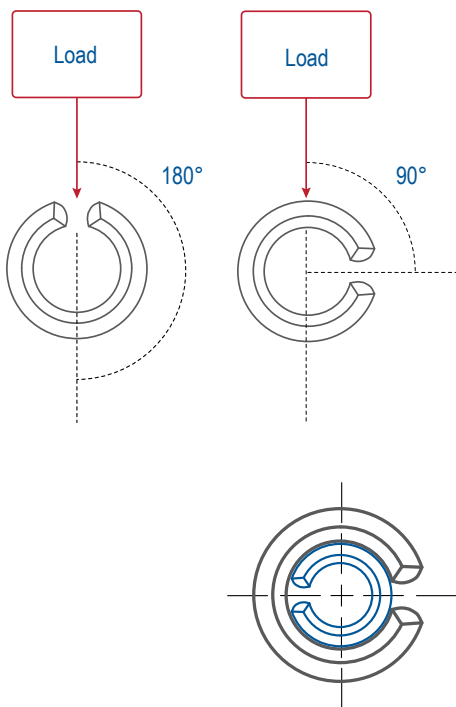

In practice, shear testing with the slot facing upwards or downwards aligned with the direction of the load results in shear forces achieved that are approximately 3-5% higher than with the slot oriented 90° to the direction of the load. This is the result of how stresses are distributed once the slot gap closes. With the slot aligned with the load, the applied loading generates symmetrical stresses within the pin along both the opposing semicircular areas. When the slot is 90° to the load, the stresses are neither uniform nor symmetrical. The disconnect where the slot is limits the load that can be carried on that half of the pin causing higher stresses to be generated on the opposite side of the pin. These localized higher stresses result in failure under lower loads than would be experienced with equally distributed stresses. The slot facing up testing method provides symmetry to the loading and results in more consistent shear values for a given lot.

COMPOSITE PIN

For applications requiring exceptionally high shear strength, it is possible to use a smaller Slotted Pin pre-installed inside the inner diameter of a larger Slotted Pin. This is commonly referred to as a Composite Pin. When using a Composite Pin, the slots should be 180° opposed, and the recommended hole size will need to be increased. It is suggested **SPIROL** Application Engineers are consulted for these situations.

LOCATING AND ALIGNMENT DESIGN

To achieve optimal alignment when using Slotted Pins, two primary design elements must be adhered to:

- 1) The hole diameters in the host and mating component must be sized accordingly to achieve the desired interference and accuracy of alignment.
- 2) In all applications, the engagement length of the Slotted Pin in the component providing primary retention must be no less than 60% of the pin's overall length. The remaining protruding length will align with the mating component. Increasing the initial length of engagement is recommended in thru-hole applications; however, the Slotted Pin still has to protrude in order to align the mating component.

Interference fit for maximum alignment accuracy:

Slotted Pins are functional springs that conform to the holes into which they are installed. The assembly force to achieve maximum accuracy in alignment should not exceed a 'light' press to seat mating components. Depending upon quantity of alignment pins, and host material, this may be as little as a tap with the palm of a hand or a mallet. An interference fit must not be confused with that of a traditional Solid Dowel which typically requires seating with pneumatic or hydraulic presses.

Clearance fit for coarse alignment and ease of assembly:

If a clearance fit over the pin is desired for ease of assembly, it will be necessary to compensate for spring recovery at the pin's free end. To determine the maximum diameter of the free end of the pin, install the pin to 60% of the pin's length into the maximum hole size of the primary retention host and measure the exposed diameter. A 0.025mm (.001") to 0.05mm (.002") clearance factor should be added to the free end of the pin depending upon desired alignment accuracy.

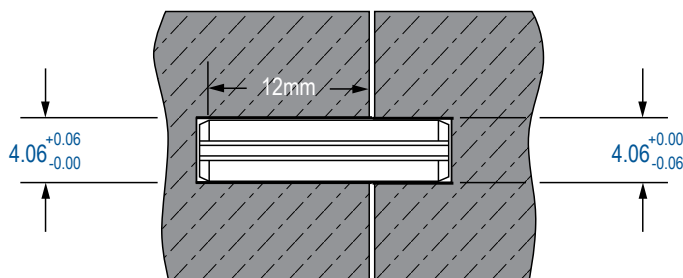

Recommended hole size and pin depth for SLTP 4 x 20 BK

SHAFT DESIGN

There are a few design guidelines that must be adhered to in order to achieve the maximum strength of the pinned system and prevent damage to the shaft and/or hub when using a Slotted Spring Pin:

Shaft – The hole in a shaft should not exceed 1/4 of the shaft diameter.

Hub – **SPIROL** recommends that the hub be designed with a minimum wall thickness of 1.5 times the diameter of the pin. Otherwise, the strength of the hub will not match the shear strength of the pin. As the wall thickness of the hub increases, so does the area of material around the pin to absorb the load.

Shaft and Hub – The diameter of the holes through both the shaft and hub should be precision matched to eliminate any movement of the pin within the holes. It is recommended that the difference between the holes not exceed 0.05mm (.002"). Otherwise, the pin will be subject to dynamic loading where a very small change in velocity could equate to an enormous change in force on the assembly. Care should be taken to ensure that the holes are drilled through the centre of the shaft and the hub.

The outer diameter (OD) of the shaft and the inner diameter (ID) of the hub should be designed such that the distance between the shear planes (OD - ID) does not exceed 0.13mm (.005"). In addition, countersinks are not recommended. Otherwise, the pin will be placed in bending and the maximum strength of the pinned system will not be achieved. This could lead to premature failure of the assembly.

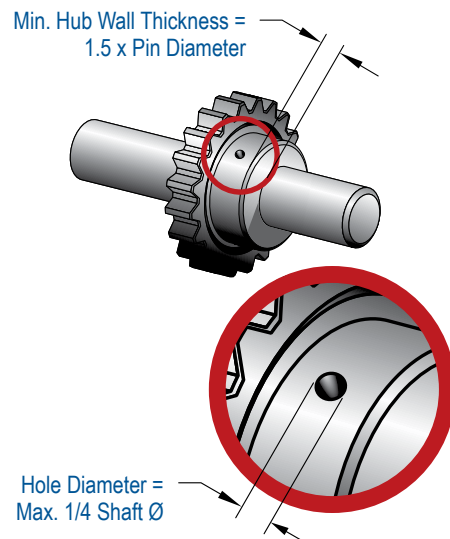

HINGE DESIGN

There are two primary types of hinges: 1) a **free fit hinge** has little to no friction or drag when the latch or handle is rotated. Hinge components are “free” to rotate independent of one another, and 2) a **friction fit hinge** requires interference to prevent free rotation of components relative to one another. Depending on design intent, resistance can vary from a slight drag to a value sufficient to maintain the fixed position of components anywhere in their full range of rotation.

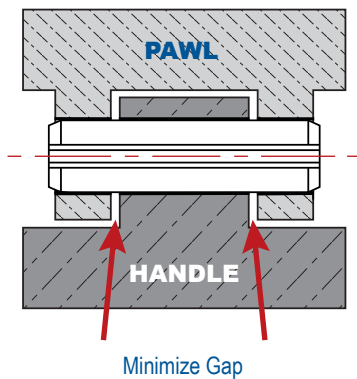

For a free fit hinge, it is recommended that the tight fit of the Slotted Pin be in the outside holes and the free fit in the centre component. To determine the hole size in the free fit (centre) component, install the pin into the maximum holes in the outside holes and measure the actual pin diameter at the centre of the pin. Add a factor of 0.03mm (.001”) to the measured diameter of the pin and specify that as the minimum hole diameter of the free fit hole and apply a positive tolerance.

For a friction fit hinge, all of the holes should be precision matched to each other. Deviations in hole sizes from one component to another will result in the reduction of hinge friction. If the manufacturer is unable to maintain the same hole size within each component, the tolerance should be split between the components. It is most common to assign the smaller half of the tolerance to the outside holes and larger half to the inside hole.

Draft angles, the direction of punched holes and the resulting die breaks/burrs need to be taken into account to ensure that the holes in both sides of the component are within specification.

HOLE DESIGN

It is important to note that the **recommended hole sizes** (on pages 3-5) may not be true for all applications. There are many applications that require a different hole size to ensure the proper function of the assembly. For this reason, it is recommended that **SPIROL** be consulted on new designs.

Even though the Slotted Pin absorbs wide hole tolerances, holding tighter tolerances, particularly in some applications such as friction fit hinges, precision alignment and shaft and gear assemblies will result in better performance.

In all cases, care must be taken to have enough material around the pin to prevent bulging and deformation of the host material. In most applications, the applied loads will far exceed the hoop stresses exerted by the Slotted Spring Pin. Never specify a non-heat-treated Slotted Pin for use in a hardened hole.

When host materials are hardened, the edges of the hole should be deburred. A countersink does not eliminate the sharp edge of a hardened hole, and instead displaces the sharp edge to the transition between the countersink and the entrance to the hole. Furthermore, countersinks increase the distance between the shear planes which can put the pin in bending and thus reduce its strength (as shown below). Cast or sintered holes should be provided with a slight lead-in radius.

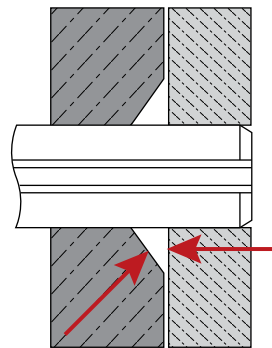

A countersink increases the distance between the shear planes. This can put the pin in bending and thus reduce the strength of the pin

Permissible Hole Misalignment – Slotted Spring Pins are capable of compensating for minor misalignment as they are manufactured with a generous lead-in chamfer. In order to determine the maximum misalignment between mating holes into which the Slotted Pin is installed, use the following calculation:

$$MPHM = \frac{1}{2} (H-B) \text{ where;}$$

MPHM = Maximum Permissible Hole Misalignment

H = Minimum hole diameter of the second hole through which the pin will be inserted

B = Chamfer diameter (assume this to be equal the “B Max” dimension listed on pages 3-5)

While **SPIROL** Slotted Pins can be easily installed with a hammer or with an arbour press, we recognize that an essential factor in reducing the overall cost of components is having trouble-free assembly. Automation increases assembly efficiency, particularly with awkward or small components, and combining operations such as drilling and pinning increases productivity and eliminates misaligned holes.

SPIROL's Standard Slotted Spring Pins were designed with automatic feeding and installation in mind. They do not nest or interlock, and have a lower insertion force compared with ISO 8752 Slotted Pins. On the contrary, while ISO Slotted Pins can be installed with Manual Pin Inserters, they are *not recommended* for use with vibratory bowl feeders due to their propensity to interlock.



Model PR
Semi-Automatic
Pin Inserter



Model CR
Heavy Duty Semi-Automatic
Pin Inserter



Model PM
Manual Pin Inserter



Model PMH
Heavy Duty Manual Pin Inserter



Model DP
Drilling & Pinning Machine

Protective eyewear is recommended during pin installation.

SPIROL is the **only** manufacturer of Slotted Pins that designs, builds and supports a comprehensive standard line of Pin Installation Equipment ranging from manual to fully automatic modules. We are experts in adapting our standard modules to customer specific applications, including fixturing and holding components for both a quality installation and ease-of-assembly. Our time-tested, proven and reliable equipment can be equipped with options such as rotary index tables, pin sensing, force monitoring, and drilling and pinning combinations for enhanced productivity, heightened process control and error proofing.

SPIROL manufactures two types of Slotted Spring Pins: SPIROL Standard Slotted Pins and ISO 8752 Slotted Pins. SPIROL Standard Slotted Pins offer significant advantages as compared to ISO 8752 Slotted Pins, which were originally designed to function as Dowel Bushings. Dowel Bushings are used in conjunction with bolts and isolate bolt threads from shear planes. Conversely, SPIROL Standard Slotted Spring Pins were designed to perform one of the following pinning functions without the addition of any other fastener: hinge, alignment, retention, stop, or hub/shaft connection. While both SPIROL Standard Slotted Spring Pins and ISO 8752 Slotted Pins can be effective in an assembly, SPIROL Standard Slotted Spring Pins are easier to install and superior in form, fit, and function.

Chamfer

SPIROL Standard Slotted Spring Pins specify a maximum chamfer diameter to facilitate the installation process and address the common issues experienced with installing ISO 8752 Slotted Pins. For example, a Ø6mm SPIROL Standard Slotted Spring Pin has a maximum chamfer diameter of Ø5.8mm, providing 1mm clearance on either side to facilitate installation into the hole.

Conversely, since ISO 8752 only requires that the maximum chamfer diameter be “less than” the nominal pin diameter, this often causes installation issues. In other words, a Ø6mm ISO 8752 Slotted Pin chamfer need only measure smaller than Ø6mm. So, for example, a value of Ø5.99mm would be acceptable, leaving only 0.0005mm on either side to help get it started into the hole.

Lower Insertion Force

SPIROL Standard Slotted Pins generally require less force to install as compared to ISO 8752 pins. To understand the difference, it is necessary to consider the pin’s starting diameter. ISO 8752 pins possess a larger ØOD, and as a result, more force is required to compress the pin during installation. On average, SPIROL Standard Slotted Spring Pins are installed with 40% less force than the equivalent ISO 8752 Slotted Pin.

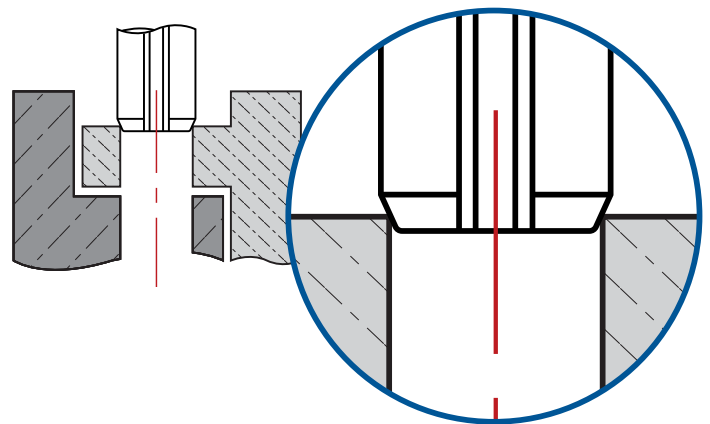

SPIROL Standard Slotted Pins sits deeper in the hole to facilitate installation

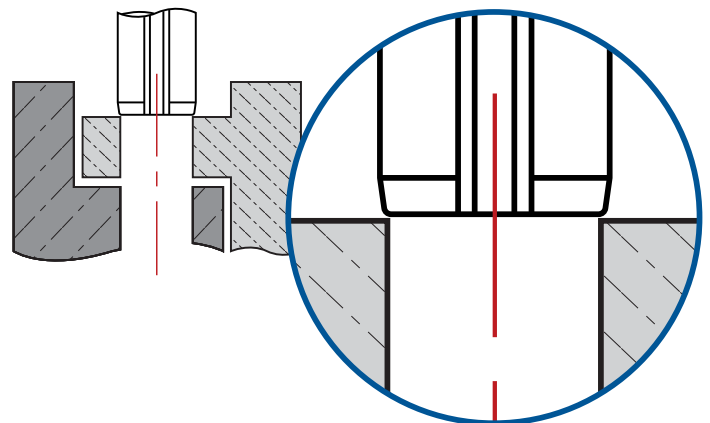

ISO 8752 Slotted Pins are often difficult to install because the chamfer diameter is not much smaller than the hole

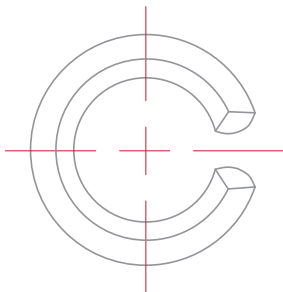

Interlocking

ISO 8752 Slotted Spring Pins are prone to interlocking. The reason for this is that ISO 8752 Slotted Pins have a slot width wider than the thickness of the raw material. Interlocking often causes feeding problems and can result in production downtime. ISO 8752 Slotted Pins will also interlock during the plating process and these nested pins may end up permanently bonding together. In the event that they become loose again during or after plating, there will be sections of the pin that have little to no plating coverage.

Conversely, SPIROL Standard Slotted Spring Pins have a maximum slot width specification less than the material thickness and thus can not interlock. Therefore, SPIROL Standard Slotted Pins can be automatically fed and installed without risk of downtime due to interlocking, and they can be plated without risk of incomplete plating coverage.

Shear Strength

Another advantage is that SPIROL Standard Slotted Pins provide greater shear strength than ISO 8752 Pins.

NOM. DIA.	ISO	SPIROL STANDARD	% STRONGER THAN ISO 8752
	DOUBLE SHEAR STRENGTH IN kN		
1.5	1.58	1.8	14%
2	2.82	3.5	24%
2.5	4.38	5.5	26%
3	6.32	7.8	23%
4	11.24	12.3	9%
5	17.54	19.6	12%
6	26.04	28.5	9%
8	42.76	48.8	14%
10	70.16	79.1	13%
12	104.1	104.1	—

Double Shear Strength Comparison Between ISO 8752 and SPIROL Standard Slotted Spring Pins

Conclusion

While SPIROL manufactures both SPIROL Standard and ISO 8752 Slotted Pins, the SPIROL Standard Slotted Pins are superior in **every category** as it relates to performance and the assembly process. There are no technical benefits with using ISO 8752 Slotted Pins. Optimize your assembly by designing in **SPIROL Standard Slotted Spring Pins!**



Example of interlocked Slotted Pins

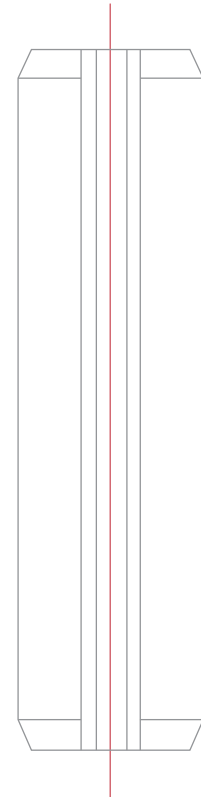



**Innovative fastening solutions.
Lower assembly costs.**

Technical Centres

Americas SPIROL Canada
3103 St. Etienne Boulevard
Windsor, Ontario N8W 5B1 Canada
Tel. +1 519 974 3334
Fax. +1 519 974 6550

SPIROL International Corporation
30 Rock Avenue
Danielson, Connecticut 06239 U.S.A.
Tel. +1 860 774 8571
Fax. +1 860 774 2048

SPIROL Shim Division
321 Remington Road
Stow, Ohio 44224 U.S.A.
Tel. +1 330 920 3655
Fax. +1 330 920 3659

SPIROL Mexico
Avenida Avante #250
Parque Industrial Avante Apodaca
Apodaca, N.L. 66607 Mexico
Tel. +52 81 8385 4390
Fax. +52 81 8385 4391

SPIROL Brazil
Rua Mafalda Barnabé Soliane, 134
Comercial Vitória Martini, Distrito Industrial
CEP 13347-610, Indaiatuba, SP, Brazil
Tel. +55 19 3936 2701
Fax. +55 19 3936 7121

Europe SPIROL United Kingdom
17 Princewood Road
Corby, Northants
NN17 4ET United Kingdom
Tel: +44 (0) 1536 444800
Fax: +44 (0) 1536 203415

SPIROL France
Cité de l'Automobile ZAC Croix Blandin
18 Rue Léna Bernstein
51100 Reims, France
Tel: +33 (0) 3 26 36 31 42
Fax: +33 (0) 3 26 09 19 76

SPIROL Germany
Ottostr. 4
80333 Munich, Germany
Tel: +49 (0) 89 4 111 905 71
Fax: +49 (0) 89 4 111 905 72

SPIROL Spain
Plantes 3 i 4
Gran Via de Carles III, 84
08028, Barcelona, Spain
Tel/Fax: +34 932 71 64 28

SPIROL Czech Republic
Evropská 2588 / 33a
160 00 Prague 6-Dejvice
Czech Republic
Tel: +420 226 218 935

SPIROL Poland
ul. Solec 38 lok. 10
00-394, Warsaw, Poland
Tel. +48 510 039 345

Asia Pacific SPIROL Asia Headquarters
1st Floor, Building 22, Plot D9, District D
No. 122 HeDan Road
Wai Gao Qiao Free Trade Zone
Shanghai, China 200131
Tel: +86 (0) 21 5046-1451
Fax: +86 (0) 21 5046-1540

SPIROL Korea
16th Floor, 396 Seocho-daero,
Seocho-gu, Seoul, 06619, South Korea
Tel: +82 (0) 10 9429 1451

e-mail: info-ca@spirol.com

SPIROL.ca



Coiled Spring Pins



Slotted Spring Pins



Solid Pins



**Alignment Dowels /
Bushings**

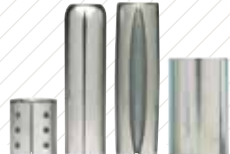

**Spacers & Rolled
Tubular Components**

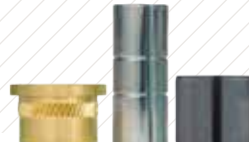

**Compression
Limiters**



**Threaded Inserts
for Plastics**



Railroad Nuts



Disc Springs



**Precision Shims &
Thin Metal Stampings**



Precision Washers



**Parts Feeding
Technology**



**Pin Installation
Technology**



**Insert Installation
Technology**



**Compression Limiter
Installation Technology**

Please refer to www.SPIROL.ca for current specifications and standard product offerings.

SPIROL offers complimentary Application Engineering support! We will assist on new designs as well as help resolve issues, and recommend cost savings on existing designs. Let us help by visiting **Application Engineering Services** on **SPIROL.ca**.